

Vortex Tube

Model 328

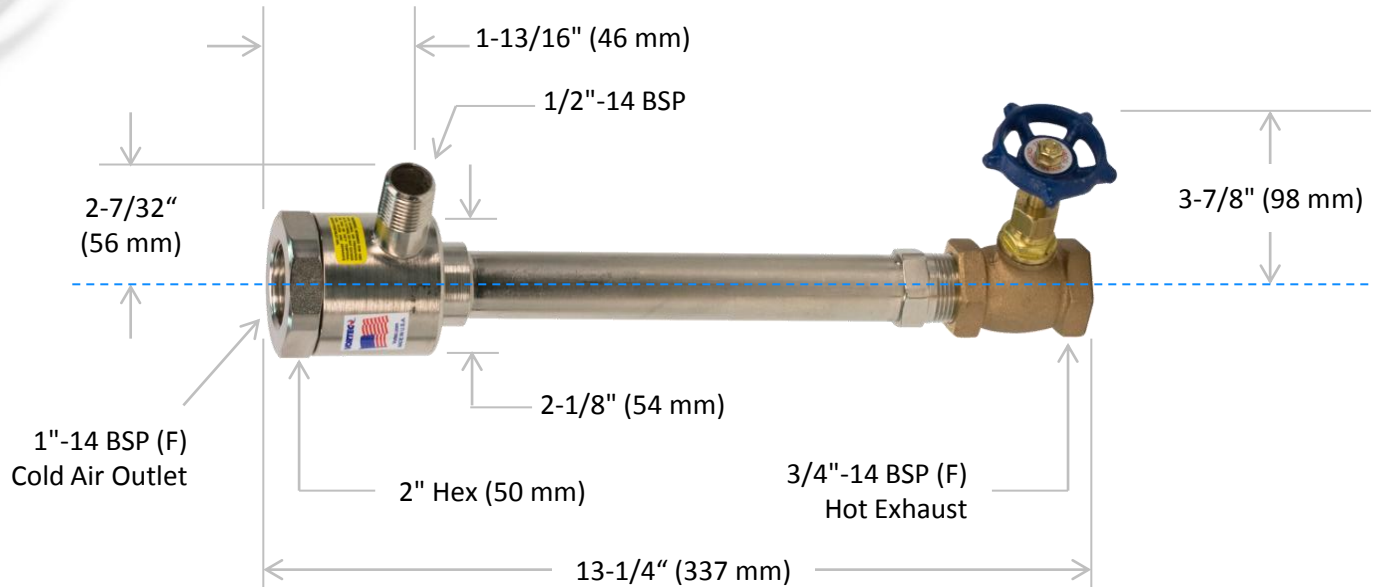

SPECIFICATIONS

Product	Cooling Capacity		Air Consumption		Inlet Size	Outlet Size	Weight	
	BTU/hr	Watts	SCFM	SLPM			lbs	kg
328-50-H	3000	879	50	1415	1/2 inch BSP (M)	1 inch BSP (F)	3.25	1.5
328-75-H	4500	1319	75	2123	1/2 inch BSP (M)	1 inch BSP (F)	3.25	1.5
328-100-H	6000	1758	100	2830	1/2 inch BSP (M)	1 inch BSP (F)	3.25	1.5

Note: Specifications are for 100 psig (6.9 bar) compressed air.